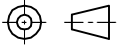

NOTES:

1. METAL GROUNDING STRAP AND STAINLESS STEEL SCREWS ARE SUPPLIED WITH COVER.

RELATED DOCUMENTS		3RD ANGLE PROJECTION		THIS DRAWING IS CONFIDENTIAL AND THE PROPERTY OF TURCK INC. USE OF THIS DOCUMENT WITHOUT WRITTEN PERMISSION IS PROHIBITED.		 3000 CAMPUS DRIVE MINNEAPOLIS, MN 55441 1-800-544-7769 (763) 553-7300 (763) 553-0708 fax www.turck.us	
1.				DRFT IK		DATE 06/23/99	
2.				DSGN		SCALE 1=2.0	
3.		ALL DIMENSIONS DISPLAYED ON THIS DRAWING ARE FOR REFERENCE ONLY  CONTACT TURCK FOR MORE INFORMATION		UNIT OF MEASUREMENT		DESCRIPTION	
4.				MILLIMETER [ INCH ]		OCA-2-30	
MATERIAL		FINISH		IDENTIFICATION NO.		REV	
				Z0004		B	
B CONVERT DRAWING TO TURCK FORMAT		CBM 08/30/04 11884		DO NOT SCALE THIS DRAWING		FILE: Z0004	
REV DESCRIPTION		BY DATE ECO NO.				SHEET 1 OF 1	